

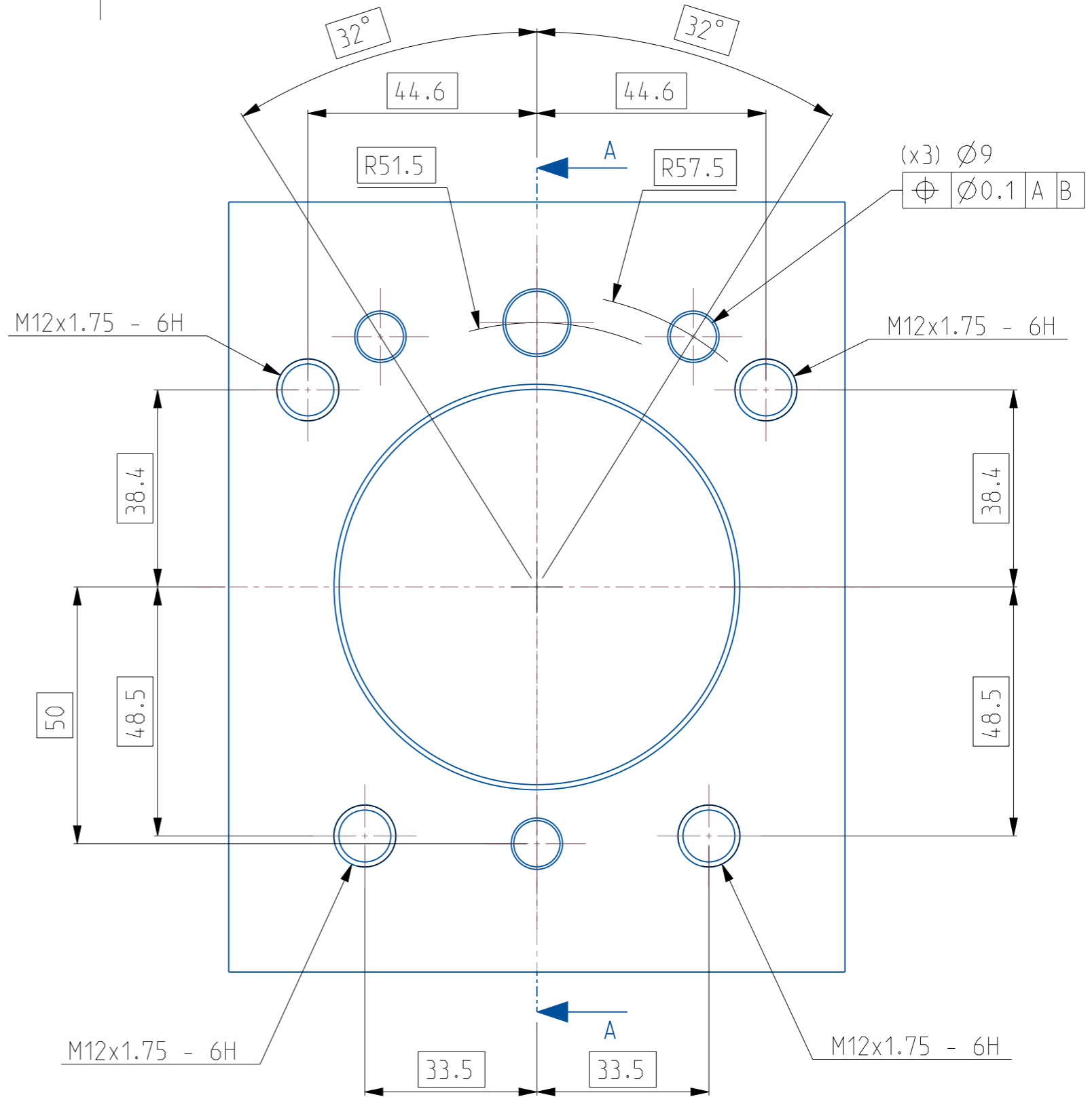

# MOUNTING PLATE EFDS106 + TELESCOPIC MODULE

## SECTION A-A

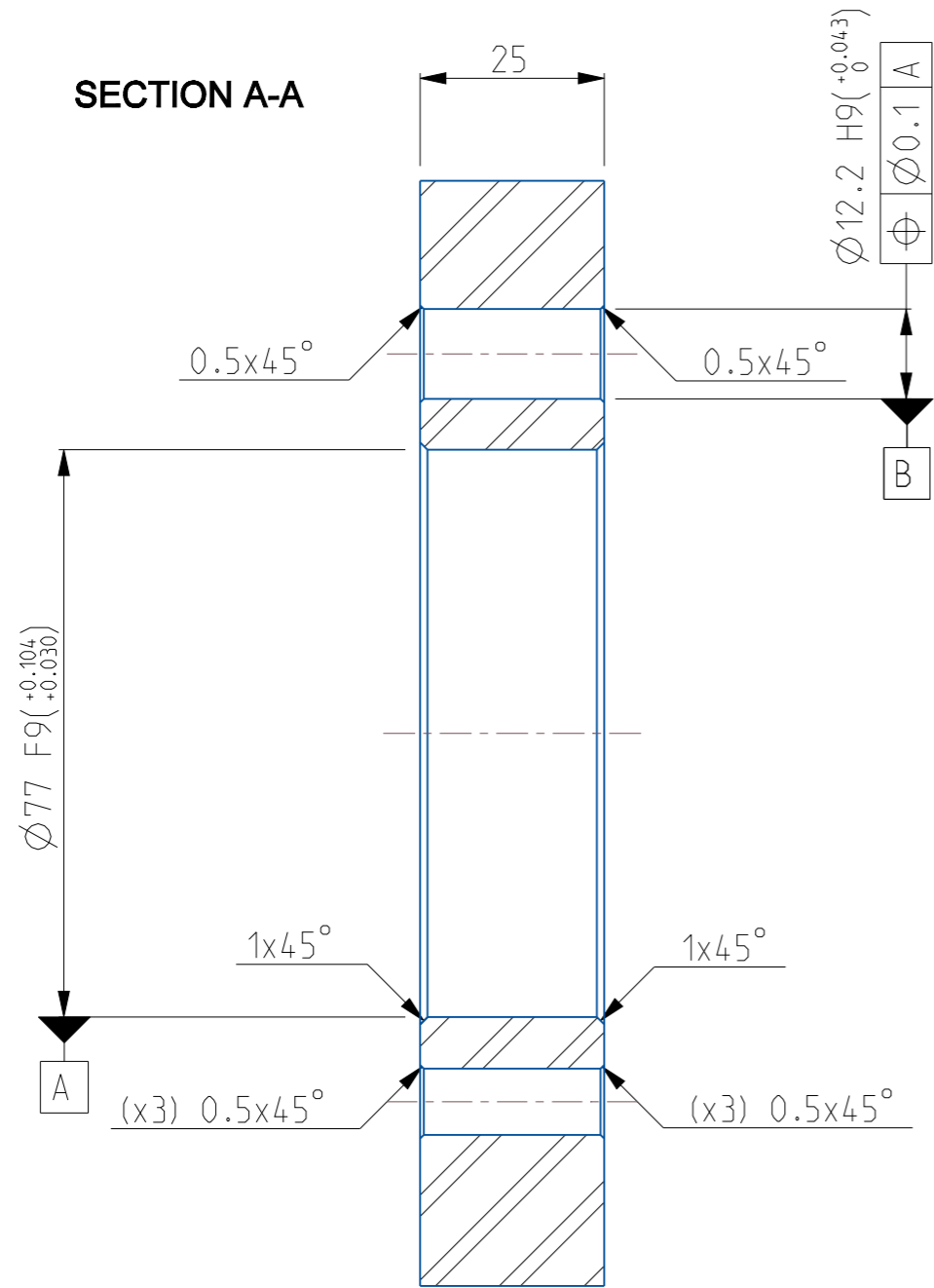

**⚠ Recommended material : Rm > 900MPa**

This document is our property and shall not without our permission be altered, copied, used for manufacturing or communicated to any other person or company. Do not get any dimensions directly from the drawing.

REV.N°	ECN.N°	POS.	MODIFICATION DETAILS	DATE YYYY/MM/DD	INIT.
02	-	-	Mounting Plate Added	2023/08/09	FPA
01	-	-	Release for Production	2022/03/28	VGU

		<b>EFD106-1100</b>		DATE YYYY/MM/DD <b>2022/03/28</b>		2 / 2	
				DRG.No <b>6151662170_DIM</b>		RELEASE LEVEL <b>Production</b>	
DRG.SIZE <b>A3</b>	MODEL NAME <b>6151662170_DIM</b>	WEIGHT <b>0.000 Kg</b>	Rev. <b>02</b>				
SCALE <b>1.0</b>	BLANK DRG. -	PROTO DRG. -	DRAWN BY <b>VGU</b>		<b>6151662170_DIM</b>		

Rev.Ver	02.0
Model Release Level	Production
Rev.Ver	02.1
Drawing Release Level	Production
Model name	6151662170_DIM
Drawing name	6151662170_DIM