

Q-SHIELD Connected

Product Instructions

Model

Q-SHIELD 30-C
Q-SHIELD 150-C
Q-SHIELD 200-C
Q-SHIELD 350-C
Q-SHIELD 400-C
Q-SHIELD 500-C
Q-SHIELD 800-C
Q-SHIELD 900-C

Part number

6159352000
6159352010
6159352020
6152210370
6159352030
6159352040
6159352050
6159352060



Download the latest version of this document at
http://www.desouttertools.com/info/6159929580_EN

⚠ WARNING**Read all safety warnings and instructions**

Failure to follow the safety warnings and instructions may result in electric shock, fire and/or serious injury.

Save all warnings and instructions for future reference

Table of Contents

Product Information	4
General Information.....	4
Website	4
Information about spare parts	4
Overview	4
General description	4
Technical information	4
Storage and use conditions.....	4
WLAN.....	5
Regulatory domain	5
Exposed network interfaces and services at factory default state	6
Torque range.....	6
Dimensions	7
Weight.....	7
Battery.....	7
Display	8
Keyboard.....	10
Vibration	10
Mini USB port.....	10
Calibration certificate.....	10
Accessories.....	10
Installation.....	12
Installation Instructions.....	12
Installing/removing the battery	12
Charging the battery.....	12
Operation.....	14
Configuration Instructions.....	14
How to connect the tool to CVIMONITOR.....	14
How to set up Psets and Assembly Processes.....	14
How to enter the password	14
How to set a new password	14
How to reset the password.....	14
How to set/display the network parameters	14
How to set/display language, date format, date and time	14
How to set the Demo mode unit of measurement.....	15
How to set/display power off and display switch off parameters.....	15
Operating Instructions	15
Powering ON / OFF the wrench.....	15
How to run a Pset.....	15
How to run an Assembly process.....	15
How to display the Psets list	15
How to display the results list.....	15
Running a Peak demo test.....	15
Running a Track demo test.....	16

Running a Tightening demo test	17
Running a VDI-VDE 2648 test (Calibration purpose).....	18
Service.....	19
Maintenance Instructions	19
Cleaning	19
Calibration	19
Battery maintenance	19
Running a Diagnostic test	19
Running the Manual Zero Adjustment process	19
Troubleshooting	21
"Error Zeroing Torque" is displayed on the Q-SHIELD screen at the power ON.....	21
"Error Zeroing Gyro" is displayed on the Q-SHIELD screen at the power ON	21
"Min Load Error" is displayed on the Q-SHIELD screen when starting a test	21
"Overload error" is displayed on the Q-SHIELD screen	21
"Capacity error" is displayed on the Q-SHIELD screen when starting a test.....	21
"WLAN" is not displayed on the Q-SHIELD screen	21
"Wrench locked" is displayed on the Q-SHIELD screen	21
Recycling.....	22
Environmental Regulations	22
Recycling information	22

Product Information

General Information

WARNING Risk of Property Damage or Severe Injury

Ensure that you read, understand and follow all instructions before operating the tool. Failure to follow all the instructions may result in electric shock, fire, property damage and/or severe bodily injury.

- ▶ Read all Safety Information delivered together with the different parts of the system.
- ▶ Read all Product Instructions for installation, operation and maintenance of the different parts of the system.
- ▶ Read all locally legislated safety regulations regarding the system and parts thereof.
- ▶ Save all Safety Information and instructions for future reference.

Website

Information concerning our Products, Accessories, Spare Parts and Published Matters can be found on the Desoutter website.

Please visit: www.desouttertools.com.

Information about spare parts

Exploded views and spare parts lists are available in Service Link at www.desouttertools.com.

Overview

General description

The Q-SHIELD is an instrument designed to perform tightening operations and quality control test in production in a secured interaction with other devices. Powered by a battery, the Q-SHIELD works as a connected Tightening Unit within Desoutter Ecosystem (CONNECT Industrial Hub); a dedicated software (CVI Suite) has been developed to program the tool, retrieve the data for further analysis, monitor the quality of the tightening process and to ensure a full traceability.

Technical information

- Operating torque range: from 10% to 100% of the capacity
- Torque static accuracy: 1% of torque reading \pm 1 digit (within the operating torque range)
- Torque overload capacity: 20% of FSD
- Minimum angular speed: 1,2 °/s
- Angle measurement accuracy:
1,2 °/s \leq angular speed $<$ 3 °/s \rightarrow 2,5 %
3 °/s \leq angular speed \leq 250 °/s \rightarrow 1,0 %
- Maximum angular speed: 250 °/s
- Stability of zero offset with temperature: \pm 0.1% of FSD/°C
- Results memory capacity: 1000
- Unit of measurement supported: N·m, kgf·m, kgf·cm, lbf·ft, lbf·in, ozf·ft, ozf·in, kp·m, dN·m
- VDI 2645-2 compliant
- ISO 6789:2017 compliant

Storage and use conditions

- Indoor Use only
- Altitude: Up to 2000m
- Ambient Temperature: 5 to 40°C
- Maximum relative humidity 80 % for temperatures up to 31 °C decreasing linearly to 50 % relative humidity at 40 °C
- Overvoltage category: II
- Environmental Class: II

- Pollution Degree: 2
- IP Grade according to EN IEC 60529 (except connector): IP40
- Power consumption: 13 W
- Operation to reduced specification over a temperature range of -10 °C to 60 °C (the battery must not be recharged when operating in this range)
- Battery operating temperature: from -20 °C to +60 °C

WLAN

- Type: IEEE 802.11a/b/g/n
- Frequency:
 - 2400 ÷ 2483.5 MHz
 - 5150 ÷ 5350 MHz indoor use only
 - 5470 ÷ 5725 MHz
- Maximum conduct output power: 15 dBm
- Maximum radiated output power: 18 dBm EIRP (RF power including maximum antenna gain (3 dBi))
- Receiver conducted sensitivity:
 - 2400 ÷ 2483.5 MHz: - 95 dBm
 - 5150 ÷ 5350 MHz indoor use only: - 90 dBm
 - 5470 ÷ 5725 MHz: - 90 dBm

Regulatory domain

A WLAN regulatory domain can be defined as a bounded area that is controlled by a set of laws or policies. Many countries follow standards set by FCC, ETSI, or worldwide.

2.4 GHz authorized channel list per regulatory domain

Channel	FCC America	ETSI Europe	Worldwide
1	x	x	x
2	x	x	x
3	x	x	x
4	x	x	x
5	x	x	x
6	x	x	x
7	x	x	x
8	x	x	x
9	x	x	x
10	x	x	x
11	x	x	x
12	N/A	x	N/A
13	N/A	x	N/A

5 GHz authorized channel list per regulatory domain

Channel	Radio band	FCC North America	ETSI Europe	Worldwide
36	U-NII-1	x	x	x
40		x	x	x
44		x	x	x
48		x	x	x

Product Information

Channel	Radio band	FCC North America	ETSI Europe	Worldwide
52	U-NII-1	x	x	x
56		x	x	x
60		x	x	x
64		x	x	x
100	U-NII-2 Ext	x	x	x
104		x	x	x
108		x	x	x
112		x	x	x
116		x	x	x
120		N/A	x	N/A
124		N/A	x	N/A
128		N/A	x	N/A
132	U-NII-3	x	x	x
136		x	x	x
140		x	x	x
149		x	x	N/A
153		x	x	N/A
157		x	x	N/A
161		x	x	N/A
165		x	x	N/A

Exposed network interfaces and services at factory default state

Network Interface

Interface	Type	Description
Wi-Fi	Wi-Fi	Used for communication with CONNECT

Torque range

Model	Minimum [Nm]	Maximum [Nm]	Overload [Nm]
Q-SHIELD 30	3	30	36
Q-SHIELD 150	15	150	180
Q-SHIELD 200	20	200	240
Q-SHIELD 350	35	350	420
Q-SHIELD 400	40	400	480
Q-SHIELD 500	50	500	600
Q-SHIELD 800	80	800	960
Q-SHIELD 900	90	900	1080

Table 1: Torque range in Nm

Model	Minimum [ft lb]	Maximum [ft lb]	Overload [ft lb]
Q-SHIELD 30	2.21	22.13	26.55
Q-SHIELD 150	11.06	110.6	132.7
Q-SHIELD 200	14.75	147.5	177.0
Q-SHIELD 350	25.81	258.1	309.7
Q-SHIELD 400	29.5	295.0	354.0
Q-SHIELD 500	36.88	368.8	442.5
Q-SHIELD 800	59.0	590.0	708.0

Model	Minimum [ft lb]	Maximum [ft lb]	Overload [ft lb]
Q-SHIELD 900	66.38	663.8	796.5

Table 2: Torque range in ft lb

Dimensions

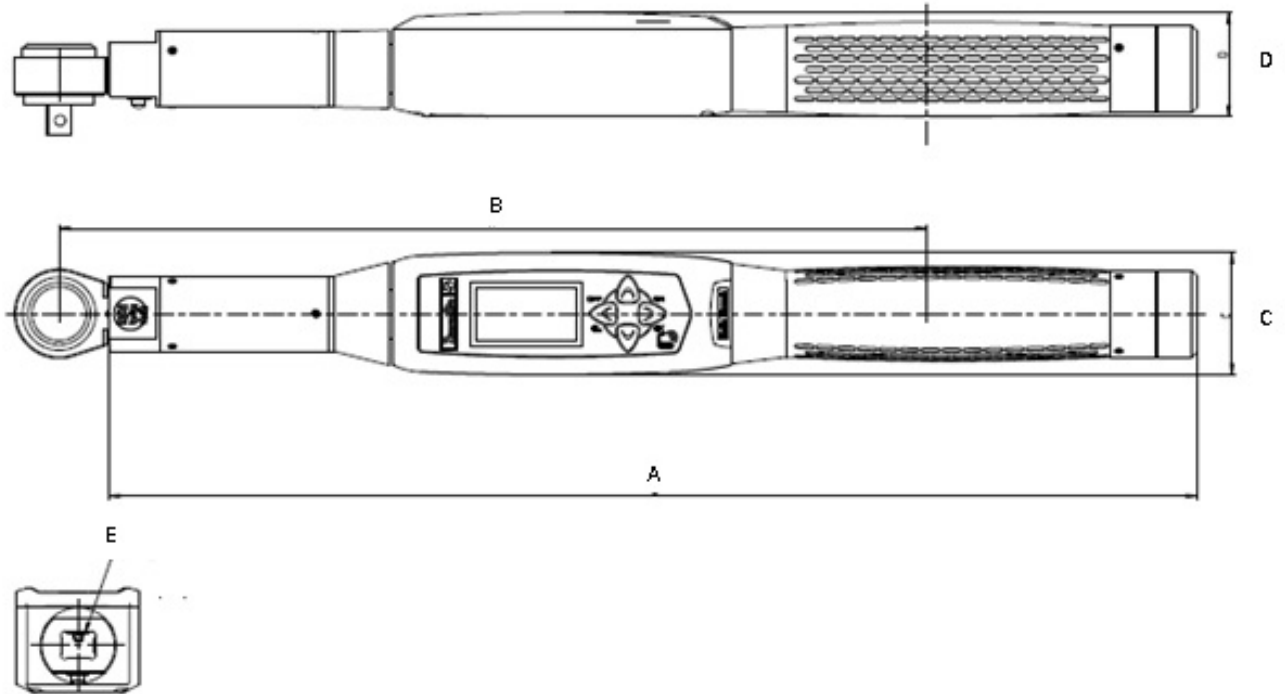

MODEL	A [mm]	B [mm]	C [mm]	D [mm]	E [mm]
Q-SHIELD 30	402	320.3	45	38.5	9×12
Q-SHIELD 150	418	342.5	45	38.5	14×18
Q-SHIELD 200	627	552.5	45	38.5	14×18
Q-SHIELD 350	694	625.5	45	38.5	14×18
Q-SHIELD 400	1028	960	45	38.5	14×18
Q-SHIELD 500	1137	1100	45	38.5	21×26
Q-SHIELD 800	1314	1362	Ø 55	Ø 55	Ø 28
Q-SHIELD 900	1392	1440	Ø 55	Ø 55	Ø 28

Weight

MODEL	Weight [kg]	Weight [lb]
Q-SHIELD 30	0.7	1.54
Q-SHIELD 150	0.8	1.76
Q-SHIELD 200	1.6	3.53
Q-SHIELD 350	2.6	5.73
Q-SHIELD 400	3.2	7.05
Q-SHIELD 500	5.5	12.13
Q-SHIELD 800	6.7	14.77
Q-SHIELD 900	8.2	18.08

Battery

- Battery power supply: Rechargeable battery, Li-ion 3.6 V, 3.5 Ah

Product Information

- Full charging time: 5 hours
- Battery life (tested at 6 tightenings per minute and connected to CONNECT):
 - 8 hours (2,4 GHz)
 - 8 hours (5 GHz)

i If the Q-SHIELD is connected, the battery life may change depending on the quantity of messages sent during connection.

Display

The Q-SHIELD display allows viewing the menus, and shows in real time the torque and the angle during the tightening operation:

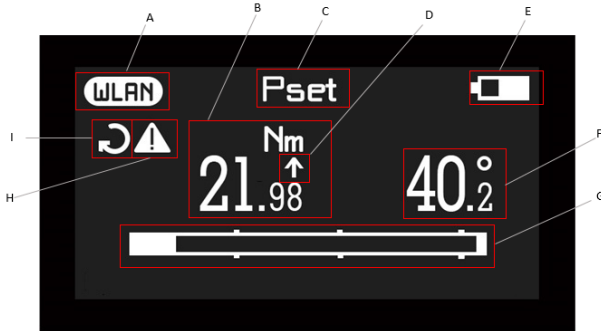

Illustration 1: Display in Pset mode

A	WLAN connection	B	Torque
C	Pset name	D	Peak
E	Battery	F	Angle
G	Progressive bar	H	Warning icon
I	Tightening direction		

- WLAN (A): it indicates the status of the wireless connection:
 - WLAN icon: connected.
 - No WLAN icon: not connected.
- Torque (B): it indicates the real time torque measurement.
- Pset name (C): it indicates the active Pset.

i In the Demo mode, it indicates Peak, Track or Tightening.

- Peak (D): the arrow placed above the torque value (or above the angle value) indicates that the result is considered at the torque peak (or angle peak).
- Battery (E): it indicates the battery charge level.
- Angle (F): it indicates the real time angle measurement.
- Progressive bar (G): it indicates the torque or angle increase (depending on the strategy), and guides the operator reaching the target value.
- Warning icon (H): it indicates that the torque applied is outside the operating torque range of the Q-SHIELD (for more information on the operating torque range, refer to the paragraphs *Technical information [Page 4]* and *Torque range [Page 6]*).
- Tightening direction (I): it indicates to the user if the tightening is clockwise or counterclockwise.

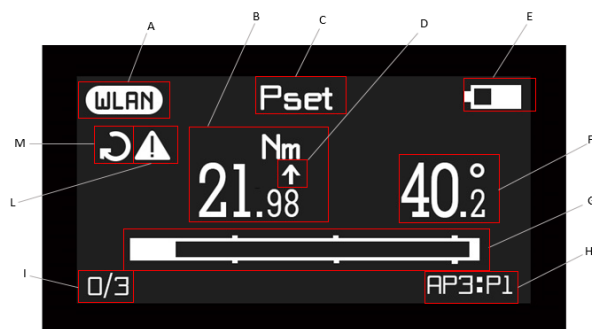

Illustration 2: Display in Assembly Process mode

A	WLAN connection	B	Torque
C	Pset name	D	Peak
E	Battery	F	Angle
G	Progressive bar	H	Assembly process number : Pset number
I	Batch count / Batch size	L	Warning icon
M	Tightening direction		





- WLAN (A): it indicates the status of the wireless connection:
 - WLAN icon: connected.
 - No WLAN icon: not connected.
- Torque (B): it indicates the real time torque measurement.
- Pset name (C): it indicates the active Pset.
- **i** In the Demo mode, it indicates Peak, Track or Tightening.
 - Peak (D): the arrow placed above the torque value (or above the angle value) indicates that the result is considered at the torque peak (or angle peak).
 - Battery (E): it indicates the battery charge level.
 - Angle (F): it indicates the real time angle measurement.
 - Progressive bar (G): it indicates the torque or angle increase (depending on the strategy), and guides the operator reaching the target value.
 - Assembly Process name (H): it indicates the active Assembly Process and Pset (as the active step in the process).
 - Batch count / Batch size (I): it indicates the progress of the number of results achieved versus the overall size of the batch to execute.
 - Warning icon (L): it indicates that the torque applied is outside the operating torque range of the Q-SHIELD (for more information on the operating torque range, refer to the paragraphs *Technical information [Page 4]* and *Torque range [Page 6]*).
 - Tightening direction (M): it indicates to the user if the tightening is clockwise or counterclockwise.

Display colors

The display background color changes according to the tightening phase and result:

- White: default color for all the menus and settings.
- Blue: when a test (or tightening) is started, the display color is blue.
- Green: during the test (or tightening) execution, the display turns green when the result is OK.
- Red: color used to indicate an error. During the test execution, the display turns red to indicate that torque and/or angle value is out of the specified min/max values of the Pset configured, or to indicate any other unwanted conditions like: memory error, system initialization error, battery not initialized, torque zero error, angle zero error, torque not calibrated, angle not calibrated, torque overload, change screw error, overspeed, rehit, Pset not present, minload error (cycle start of the Pset is below the transducer minimum torque), capacity error (torque max or change screw values of the Pset are over the transducer maximum torque), batch error.

Keyboard

Button	Name	Description
	ON / ENTER	Power ON the Q-SHIELD / Enter menu and confirm
	OFF / CANCEL	Power OFF the Q-SHIELD / Exit menu and cancel
	UP	Up (browse menu) / Increase values in settings menus
	DOWN	Down (browse menu) / Decrease values in settings menus

Vibration

The Q-SHIELD features a vibration module to provide more indications on the result of the current operation.



For Pset it is possible to set the parameter **Vibration start (% / Nm / Deg)** as a value expressed as torque, as angle, or as a percentage of the target torque. If during the test the tightening is within the limits (Min/Max Torque and Min/Max Angle) the vibration is continuous; if the tightening is out of the limits (Min/Max Torque and Min/Max Angle), the vibration is alternate.

- i** For Tightening Demo mode the wrench starts vibrating after getting 95% of the target torque. During the demo test, if the tightening is more than 5% over the target torque, the vibration is alternate.

At the end of the test:

- if the tightening is OK, the wrench vibrates for three times at a specified interval (1 second)
- if the tightening is NOK, the wrench vibrates at specified intervals continuously.

To stop the vibration:

- Start a new tightening.
- Press ENTER () → the Q-SHIELD is ready for a new measurement.
- Press CANCEL () → the Q-SHIELD exits from the test.

Mini USB port

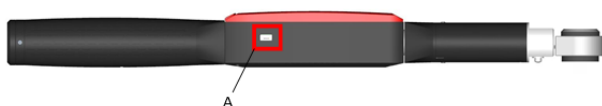

A Mini USB port

The mini USB port is marked with the following symbol: 

The mini USB port is available for programming the Q-SHIELD with CVI Suite, and to do the pairing with CONNECT. For more information, refer to the *CVI CONFIG Configuration manual* and to the **CONNECT Product Instructions**.

- i** The mini USB port is also used for firmware upgrade (reserved to authorized Desoutter Service Personnel).

Calibration certificate

Q-SHIELD has a Desoutter factory calibration certificate, please contact Desoutter Service for the specific calibration certificate.

Accessories

Overview

Name	Part number
Battery	6159365000
Battery charger	6159361510
Wrench Protection	6159365040

The wrench protection cover protects the Q-SHIELD electronic housing from accidental impacts during operations and from scratches in case of accidental contact.



To install the protection cover, slide the cover from the rear of the wrench.

End fittings

OPEN END metric

OPEN END inches



RING BOX END metric

RING BOX END inches



FLARED END metric

FLARED END inches



REVERSIBLE RATCHET



BLANK END



BITS HOLDER

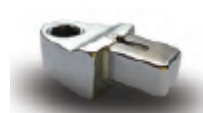

FIXED SQUARE DRIVE



End-fitting tools / Extensions

Use only end-fitting tools supplied by Desoutter (refer to the catalogue).

⚠ WARNING Crushing Hazard

Never install wrong end-fitting tools and/or extensions on the wrench. Wrong end-fitting tools and/or extensions can lead to a sudden mechanical release, which causes severe bodily injury.

- ▶ Use only end-fitting tools designed for this specific wrench.
- ▶ When using an extension, calculate the Torque Correction Coefficient and Angle Correction Coefficient (for more information on the Torque and the Angle Correction Coefficients, refer to the Configuration manual of the tool). A wrong Torque or Angle Correction Coefficient leads to an incorrect torque or angle reading and thus to an overload of the wrench.

Installation

Installation Instructions

Installing/removing the battery



To install the battery in the Q-SHIELD:

1. Unscrew the battery cap placed on the Q-SHIELD handle.
2. Insert the battery into the handle.
3. Reinstall the battery cap.

To remove the battery from the Q-SHIELD:

1. Power OFF the Q-SHIELD.
2. Unscrew the battery cap placed on the Q-SHIELD handle.
3. Remove the battery from the handle.
4. Reinstall the battery cap.

Charging the battery

i Never replace a battery without powering OFF the equipment first; removing the battery without powering OFF the wrench is likely to affect the time to restore the communications when powered ON, and can also corrupt the internal memory of the wrench.

When the Q-SHIELD battery level is low:

1. Power OFF the Q-SHIELD and remove the battery.
2. Plug the battery charger into the socket.
3. Insert the battery into the battery charger (see figure below):



The three LEDs on the battery charger show the charging status of the battery:

LEDs status	POWER ON	CHARGING	COMPLETE
Power on	●		
Charging in progress	●	●	
Charging complete	●		●

LEDs status	POWER ON	CHARGING	COMPLETE
Over temperature	●	Blinking	
Error	●	●	●

In case of over temperature:

1. Remove the battery from the battery charger.
2. Unplug the battery charger from the socket. Wait for a few minutes.
3. Plug the battery charger into the socket and insert the battery into the battery charger.
4. Verify that the problem is solved.

In case of Error: remove and then insert the battery into the battery charger and verify that the problem is solved.

Operation

Configuration Instructions

How to connect the tool to CVIMONITOR

1. Power ON the Q-SHIELD.
2. Use the mini USB port of the tool to connect the Q-SHIELD to the USB port of the computer.
3. Launch CVIMONITOR on the computer.

 For further information, refer to the CVI CONFIG Configuration manual.

How to set up Psets and Assembly Processes

To create Psets and Assembly Processes and transfer them to the Q-SHIELD, refer to the CVI CONFIG Configuration manual.

How to enter the password



 The default password is **001**.

To access the Q-SHIELD menus protected by password:



1. From the main menu of the Q-SHIELD, select the **Settings > Password > Enter password** menu.
2. Use the buttons on the Q-SHIELD keyboard to increase/decrease the values and enter the password.
3. Press the ENTER () button on the Q-SHIELD keyboard to confirm.

How to set a new password

 The default password is **001**.

1. From the main menu of the Q-SHIELD, select **Settings > Password > Set password**.
 The Set password menu can be accessed only by entering the password in the Settings > Password > Enter password menu of the Q-SHIELD.
2. Use the buttons on the Q-SHIELD keyboard to increase/decrease the values and create a new password. The maximum number of digits is 3.
3. Press the ENTER () button on the Q-SHIELD keyboard to set the new password.

How to reset the password

1. From the main menu of the Q-SHIELD, select **Settings > Password**.
2. Press at the same time both the UP () and DOWN () buttons of the Q-SHIELD keyboard.
3. Select **Reset password** and press the ENTER () button.

The password is reset to its default value: **001**.

How to set/display the network parameters

To change the network parameters of the Q-SHIELD, refer to the CVI CONFIG Configuration Manual.

To display the IP address of the Q-SHIELD, from the main menu of the Q-SHIELD select the **Settings > WLAN** menu.

 The WLAN menu is not available if the Q-SHIELD is used in Disconnected mode.

How to set/display language, date format, date and time

To change the language, the date format and the date and time of the Q-SHIELD, refer to the CVI CONFIG Configuration manual.

To display the language and the date format on the Q-SHIELD, from the main menu select respectively: Settings > Language; Settings > Date.

How to set the Demo mode unit of measurement

1. From the main menu of the Q-SHIELD, select **Settings > Demo mode unit**.
2. Browse the available unit of measurements and press the ENTER () button on the Q-SHIELD keyboard to confirm the selection.

How to set/display power off and display switch off parameters

This mode allows to save battery energy in case the wrench is ON but not used over a period of time between 2 batches.

To change the power off and display switch off parameters, refer to the CVI CONFIG Configuration manual.

To display the power off and switch off parameters on the Q-SHIELD, from the main menu select respectively the **Settings > Power off** menu, and the **Settings > Switch off** menu.

Operating Instructions

Powering ON / OFF the wrench



To power ON the wrench:

1. Attach the battery to the wrench (refer to *Installing/removing the battery [Page 12]*).
2. Make sure the wrench lays steady without any torque constraints.
3. Press the **ON / ENTER** button  on the Q-SHIELD keyboard.

To power OFF the wrench:

Press the **OFF / CANCEL** button  on the Q-SHIELD keyboard.



How to run a Pset

1. From the main menu of the Q-SHIELD, select the **Psets > Pset list** menu.
2. Use the UP () and DOWN () buttons to browse the list.
3. Select the Pset to run and press the ENTER () button to start the test.



How to run an Assembly process

To select and transfer an Assembly Process, refer to the CVI CONFIG Configuration manual.

How to display the Psets list

From the main menu of the Q-SHIELD, select the **Psets > Pset list** menu, and use the UP () and DOWN () buttons to browse the list of Psets and display the details of each Pset.

How to display the results list

From the main menu of the Q-SHIELD, select the **Results > Result list** menu, and use the UP () and DOWN () buttons to browse the list of results and display the details of each result.

Running a Peak demo test

 This feature is protected by password. Please refer to *How to enter password [Page 14]* section.

To start a Peak demo test, from the main menu of the Q-SHIELD select the **Demo mode > Peak** menu, then press the ENTER () button.

The Peak mode can be used to run a very simple tightening operation in which the operator tightens the screw at the desired torque, monitoring the torque applied on the Q-SHIELD display.



Starting from the Min. Load value, the Q-SHIELD displays the torque and angle values in real time. Once reached, the peak torque value is frozen on the display.

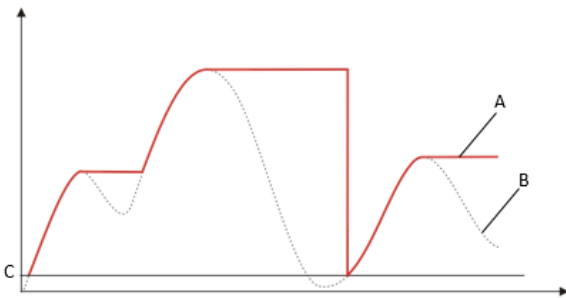

Illustration 3: Torque vs Time

A	Displayed torque	B	Applied torque
C	Minimum load		

A new cycle starts when the applied torque is released, and then applied again over the Min. Load of the Q-SHIELD (which corresponds to 1% of the Q-SHIELD capacity). The angle calculation is reset when a new test is started. By pressing the ENTER (↵) button on the Q-SHIELD keyboard, the torque and angle values are reset.

The torque must be applied in the clockwise direction.

Running a Track demo test

i This feature is protected by password. Please refer to *How to enter password [Page 14]* section.

To start a Track demo test, from the main menu of the Q-SHIELD select the **Demo mode > Track** menu, then press the ENTER (↵) button.

The Track mode can be used to run a very simple tightening operation in which the operator tightens the screw at the desired torque, monitoring the torque applied on the Q-SHIELD display.

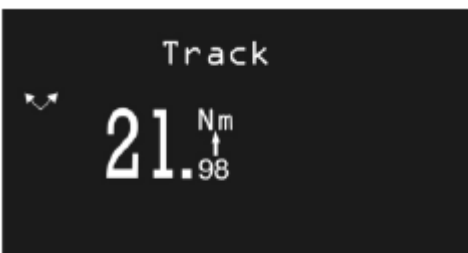

In Track mode, the Q-SHIELD displays the applied torque in real time.

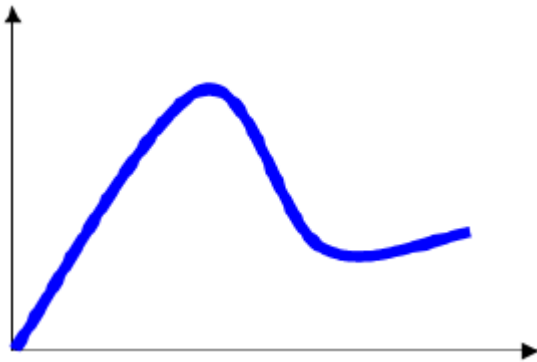

Illustration 4: Torque vs Time

Torque can be applied in either the clockwise (positive torque) or counterclockwise (negative torque) direction.

By pressing the ENTER (▶) button on the keyboard, the Q-SHIELD runs a torque zero adjustment.

- ❶ The zero adjustment is applied only for the current test; it is not applied as a global zero reference for the Q-SHIELD.

Running a Tightening demo test

- ❶ This feature is protected by password. Please refer to *How to enter password [Page 14]* section.

To start a Tightening demo test, from the main menu of the Q-SHIELD select the **Demo mode > Tightening** menu, then press the ENTER (▶) button.

The tightening mode runs a tightening operation to the target torque set.

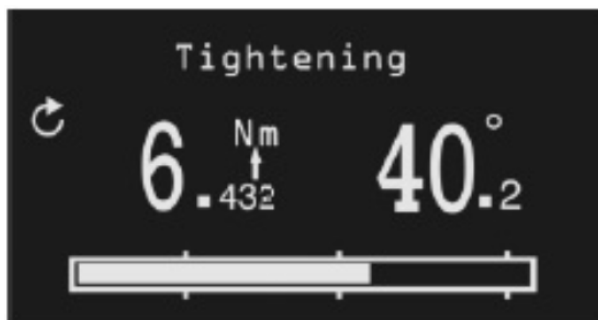

To set the target torque, press the UP (▲) and DOWN (▼) buttons; then, press the ENTER (▶) button to confirm the target torque and start the test.

The Q-SHIELD screen displays the following information:



- Torque and angle: the torque and angle values are shown in real time starting from the minimum load.
- Tightening direction: it must be clockwise.
- Progress bar: the progress bar leads the operator to reach the target value, with three markers placed at the 30%, 60% and 95% of the target torque.
- Display color:
 - Blue: default color.
 - Green: target value reached (within 5% more of the specified target torque).
 - Red: torque over the 105% of the target value.
- Vibration: the Q-SHIELD starts vibrating at 95% of the target torque. During the demo test, if the torque is 5% more than the target torque, the vibration is alternate. At the end of the demo test, if the tightening is OK, the Q-SHIELD vibrates for three times at a specified interval (1 second). If the tightening is NOK, the Q-SHIELD vibrates at specified intervals continuously; stop the vibration in one of the following ways:
 - Do a new tightening.
 - Press ENTER (▶) → the Q-SHIELD is ready for a new measurement.

- Press CANCEL () → the Q-SHIELD exits from the test.

Running a VDI-VDE 2648 test (Calibration purpose)

- ① This feature is protected by password. Please refer to *How to enter password [Page 14]* section.
- ① The Calibration mode is available only for Q-SHIELD used in Disconnected mode.

To start the angle calibration according to VDI-VDE 2648 standard, from the main menu of the Q-SHIELD select the **Calibration mode > VDI-VDE 2648** menu, then press the ENTER () button.

Use the UP () and DOWN () buttons to increase/decrease the value and set the angle threshold.

After starting the test, apply torque on the joint. The Q-SHIELD display is as follows:



- Torque and Angle: the torque is shown at torque peak, the angle at angle peak. Once the operator starts applying torque, the angle is reset only in one of the following cases:
 - after pressing the ENTER () button (also the displayed torque value is reset)
 - after releasing the Q-SHIELD to a torque value lower than its Min. Load, and then starting a new tightening operation in the opposite direction.
- Tightening direction: both clockwise and counterclockwise directions.
- Display color:
 - Blue: default color.
- Vibration: not applicable.

Service

Maintenance Instructions

Cleaning

Keep the Q-SHIELD clean.

It is very important to keep clean the area between the Q-SHIELD body and transducer (see figure below). If the Q-SHIELD is not kept clean, the transducer might not operate properly, thus altering the torque reading.

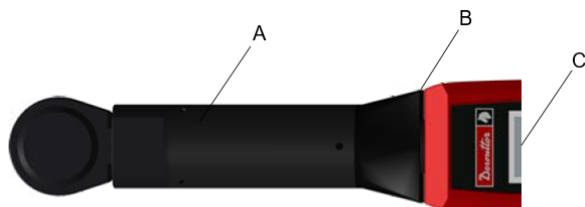

A	Transducer	B	Area to clean
C	Body		

- ❗ A wrench protection (6159365040) is proposed as an optional accessory. This protection can help to avoid swarf or dust in the junction between the transducer and the body of the wrench.

After use, remove any curves of oil, grease and dust from the Q-SHIELD, especially from the display, the keyboard, and the connectors.

Avoid using harsh detergents to clean the Q-SHIELD.

Calibration

The Q-SHIELD must be calibrated at least once a year. Contact Desoutter Service for calibration.

Battery maintenance

Keep batteries in a good working order.

Avoid fully discharging the battery. During normal use, recharge the battery when it is low. For long term storage (as in the case of spare batteries), cells should be kept within a range of a $30\% \pm 15\%$ charge. Follow these important rules:

- Store the battery in a dry place not exceeding 30°C .
- Recharge the battery for one hour every six months.

After long-term storage, fully recharge the battery before use.

Running a Diagnostic test

- ❗ This feature is protected by password. Please refer to *How to enter password [Page 14]* section.

To start a diagnostic test to check the status of the wrench hardware, from the main menu of the Q-SHIELD select the **Settings > Diagnostics** menu, then press the ENTER (▶) button.

The diagnostic procedure is interactive: follow the instructions given on the Q-SHIELD display to complete the diagnostic. If a test gives a Not OK result, the corresponding component needs to be repaired or replaced.

- ❗ If the test on the keyboard buttons of the Q-SHIELD gives a Not OK result, all the tests requiring the operator to use that button to confirm the test result will not be performed and marked as N.A. (Not Applicable).

The Q-SHIELD stores the last ten diagnostic tests. To retrieve the report of the diagnostic tests, refer to the CVI CONFIG Configuration Manual.

Running the Manual Zero Adjustment process



An automatic Zero Adjustment (Torque / Angle / WLAN) occurs each time the wrench is powered ON. When the wrench is powered ON, it should lay steady and without applying any torque constraint.

A manual Zero Adjustment is possible at any time when the wrench is already powered ON, and is highly recommended in case of an accidental wrench drop or shock.

The Zero Adjustment is also a warranty that Torque and Angle measurements are precise (in case of a NOK - restart the process - if you get a NOK systematically get the wrench to maintenance for a complete inspection and eventual calibration).

The manual Zero Adjustment of the transducer and gyroscope prevents that the Zero Gyro and the Zero Torque change over time. The manual Zero Adjustment can be started in four circumstances (provided the Q-SHIELD is in a steady position without applying any torque to the transducers):

- when the Q-SHIELD is in the main menu;
- when the Q-SHIELD is in the Demo mode menu;
- when the Q-SHIELD is in the Psets list;
- when the Q-SHIELD is in the measure screen.

To start the manual Zero Adjustment, lay down the wrench and press at the same time the UP  and DOWN  buttons of the Q-SHIELD keyboard.

Once the manual Zero Adjustment process is complete, the operator must perform a data analysis of the manual Zero Adjustment results in order to complete the measures successfully.

CASES	Torque Angle	Automatic Zero Adjustment re- sult	Manual Zero Adjustment re- sult	DATA ANALYSIS
1	Torque Angle	OK OK	OK OK	In this case, the values measured during the automatic Zero Adjustment process are updated, since the manual Zero Adjustment process is OK. The operator can proceed with the measures.
2	Torque Angle	OK OK	NOK ---	In this case, since the torque measured during the manual Zero Adjustment is NOK, the angle (during the manual Zero Adjustment) is not measured. The Q-SHIELD takes into account the last previous valid values measured. The operator can proceed with the measures.
3	Torque Angle	OK OK	OK NOK	In this case, the angle measured during the manual Zero Adjustment is NOK, therefore it takes into account the last valid angle value measured previously. On the other hand, the torque measured during the automatic Zero Adjustment is updated, since the respective value measured during the manual Zero Adjustment is OK. The operator can proceed with the measures.

Troubleshooting

“Error Zeroing Torque” is displayed on the Q-SHIELD screen at the power ON

Cause: Q-SHIELD is powered on with a load applied.

Solution: Switch off the Q-SHIELD; then, switch on the Q-SHIELD again, without applying any torque.

“Error Zeroing Gyro” is displayed on the Q-SHIELD screen at the power ON

Cause: Q-SHIELD has been moved during the power on phase.

Solution: Switch off the Q-SHIELD; then, switch on the Q-SHIELD again, leaving it in a steady position during the power on phase.

“Min Load Error” is displayed on the Q-SHIELD screen when starting a test

Cause: Pset data do not match the Q-SHIELD data.

Solution: Check the Pset data; all the parameters must be greater than the minimum load.

“Overload error” is displayed on the Q-SHIELD screen

Cause: Q-SHIELD has been overloaded.

Solution: The message is shown each time the Q-SHIELD is switched on. To reset the overload condition, the Q-SHIELD must be calibrated.

“Capacity error” is displayed on the Q-SHIELD screen when starting a test

Cause: Pset data do not match the Q-SHIELD data.

Solution: Check the Pset data; all the parameters must be lower than the Q-SHIELD capacity.

“WLAN” is not displayed on the Q-SHIELD screen

Cause: There is no communication with the system.

Solution: Check WI-FI parameters, IP addresses and communication port in the system, tool and WI-FI access point.

“Wrench locked” is displayed on the Q-SHIELD screen

Cause 1: The remote system is locking the wrench.

Solution 1: Check the settings of the tightening processes (Pset and Assembly Process).

Cause 2: The Wi-Fi connection with the remote system is not working.

Solution 2: Check the Wi-Fi settings; check the “Lock tool at disconnection” setting.

Cause 3: The maximum number of offline results is reached.

Solution 3: Check the Wi-Fi connection; check the “Block tool if results buffer is full” setting.

Cause 4: The wrench is locking after completing the Assembly Process.

Solution 4: Check the settings of the Assembly Process.

Cause 5: The wrench is locking after reaching the maximum number of retries in a batch.

Solution 5: Check the settings of the Assembly Process.

Cause 6: The Pset has been deleted during Assembly Process execution.

Solution 6: Check the settings of the Assembly Process.

Recycling

Environmental Regulations

When a product has served its purpose it has to be recycled properly. Dismantle the product and recycle the components in accordance with local legislation.

Batteries shall be taken care of by your national battery recovery organization.

Recycling information

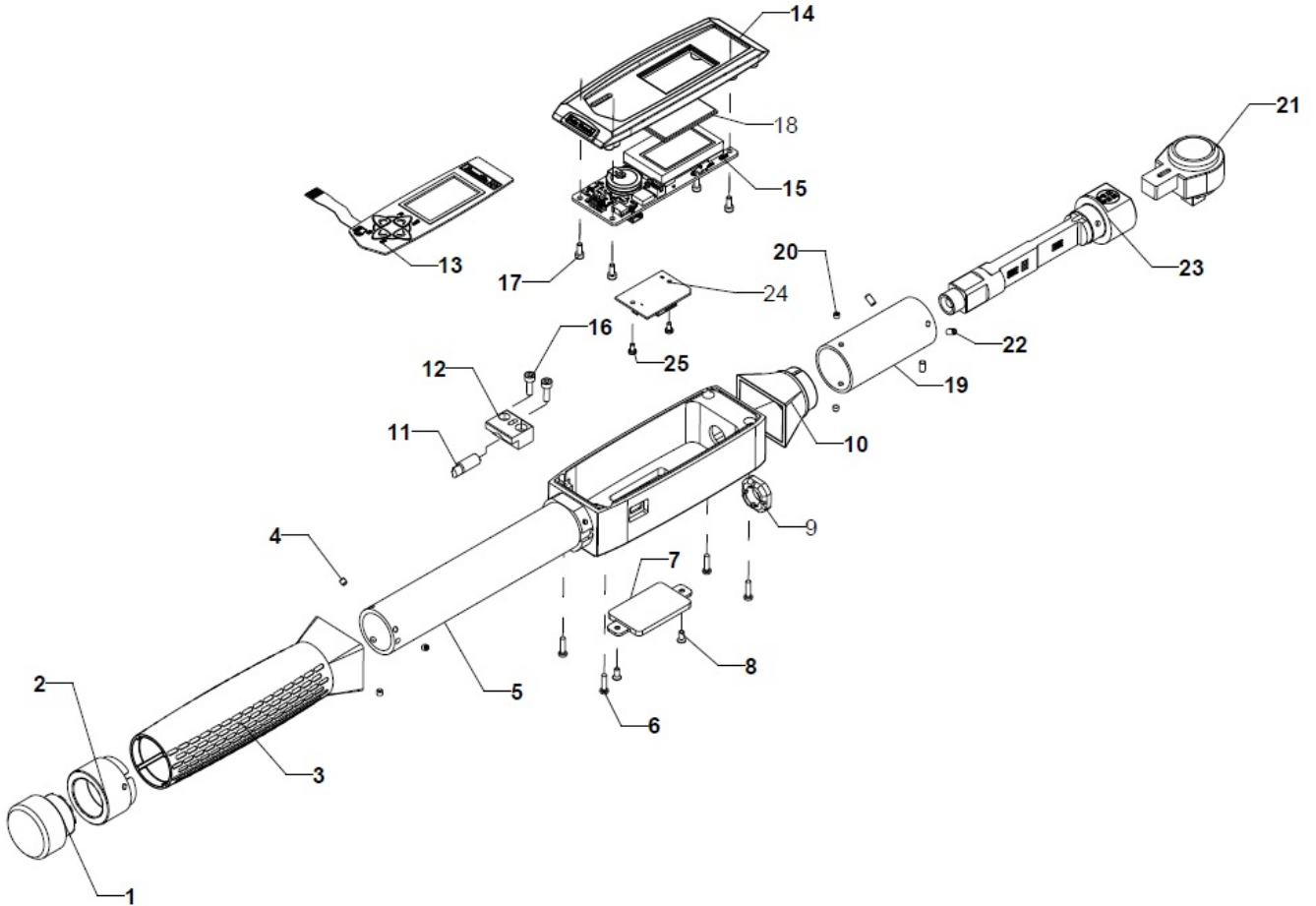

	Part	Recycle as
1	Closing cap	Aluminum
2	Handle ring	Aluminum
3	Handle	Plastic
4	Screw	Steel
5	Body	Aluminum
6	Screw	Steel
7	Radio module cover	Aluminum
8	Screw	Steel
9	Transducer locking nut	Steel
10	Transducer front cover	Plastic
11	Vibra call	WEEE
12	Vibro support	Aluminum
13	Keyboard	WEEE
14	Upper body	Mixed waste
15	Stand alone board	WEEE
16	Screw	Steel
17	Screw	Steel

	Part	Recycle as
18	Slide display	WEEE
19	Transducer end cover	Aluminum
20	Screw	Steel
21	Ratchet	Steel
22	Screw	Steel
23	Transducer	Steel
24	Wi-Fi module	Plastic
25	Screw	Steel

Original instructions

Founded in 1914 and headquartered in France, Desoutter Industrial Tools is a global leader in electric and pneumatic assembly tools serving a wide range of assembly and manufacturing operations, including Aerospace, Automotive, Light and Heavy Vehicles, Off-Road, General Industry.

Desoutter offers a comprehensive range of Solutions -tools, service and projects- to meet the specific demands of local and global customers in over 170 countries.

The company designs, develops and delivers innovative quality industrial tool solutions, including Air and Electric Screwdrivers, Advanced Assembly Tools, Advanced Drilling Units, Air Motors and Torque Measurement Systems.

Find more on www.desouttertools.com



More Than Productivity