

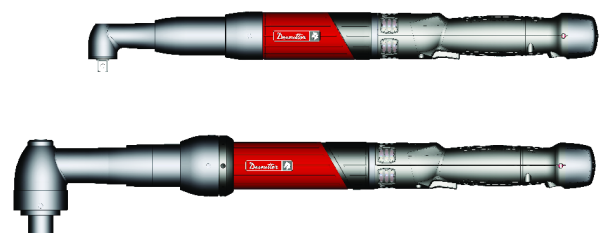

# Angle-head Electric Nutrunner

## Product Instructions

| Model           | Part number |
|-----------------|-------------|
| EAD20-1300      | 6151656060  |
| EAD32-900       | 6151656070  |
| EAD50-900       | 6151656090  |
| EAD50-900-HAD   | 6151658770  |
| EAD70-800       | 6151656110  |
| EAD70-700-HAD   | 6151658780  |
| EAD70-800 SQ1/2 | 6151658820  |
| EAD80-650       | 6151656120  |
| EAD105-500      | 6151656130  |
| EAD105-500-HAD  | 6151658790  |
| EAD160-430      | 6151656810  |
| EAD160-430-HAD  | 6151658800  |
| EAD200-370      | 6151656820  |
| EAD280-260      | 6151656830  |
| EAD280-370      | 6151656840  |
| EAD440-250      | 6151656850  |
| EAD660-160      | 6151656860  |



Download the latest version of this document at  
[http://www.desouttertools.com/info/6159929650\\_EN](http://www.desouttertools.com/info/6159929650_EN)

|   |  |
|---|--|
|  | ⚠ WARNING  |
|   | <b>Read all safety warnings and instructions</b><br>Failure to follow the safety warnings and instructions may result in electric shock, fire and/or serious injury. |
|   | <b>Save all warnings and instructions for future reference</b>   |

# Table of Contents

|   |           |
|---|-----------|
| <b>Product Information .....</b>                | <b>3</b>  |
| General Information.....                        | 3         |
| Safety Signal Words.....                        | 3         |
| Warranty.....                                   | 3         |
| Website .....                                   | 3         |
| Information about spare parts .....             | 3         |
| Dimensions (mm).....                            | 4         |
| CAD files .....                                 | 6         |
| Overview .....                                  | 6         |
| General overview .....                          | 6         |
| Product description .....                       | 6         |
| Technical data.....                             | 7         |
| Accessories.....                                | 9         |
| Service Overview .....                          | 11        |
| Maintenance program .....                       | 11        |
| Spare parts.....                                | 11        |
| <b>Installation.....</b>                        | <b>12</b> |
| Installation Instructions.....                  | 12        |
| How to clamp the tool.....                      | 12        |
| Connecting the tool to the controller .....     | 13        |
| Mounting the trigger locker.....                | 13        |
| How to install optional accessories .....       | 13        |
| <b>Operation.....</b>                           | <b>14</b> |
| Configuration Instructions.....                 | 14        |
| How to set up the reverse mode .....            | 14        |
| How to set up the tool as a fixtured tool ..... | 14        |
| Operating Instructions .....                    | 14        |
| Starting the tool .....                         | 14        |
| How to reverse the rotation .....               | 14        |
| Tightening status and LED reporting.....        | 15        |
| <b>Service.....</b>                             | <b>16</b> |
| Maintenance Instructions .....                  | 16        |
| Instructions for transducerized tools .....     | 16        |
| Read before maintenance.....                    | 16        |
| Preventive Maintenance.....                     | 16        |
| Upgrading tools .....                           | 16        |
| Checking before putting back into service.....  | 17        |
| Recommissioning .....                           | 17        |

## Product Information

### General Information

#### **WARNING Risk of Property Damage or Severe Injury**

Ensure that you read, understand and follow all instructions before operating the tool. Failure to follow all the instructions may result in electric shock, fire, property damage and/or severe bodily injury.

- ▶ Read all Safety Information delivered together with the different parts of the system.
- ▶ Read all Product Instructions for installation, operation and maintenance of the different parts of the system.
- ▶ Read all locally legislated safety regulations regarding the system and parts thereof.
- ▶ Save all Safety Information and instructions for future reference.

### Safety Signal Words

The safety signal words **Danger**, **Warning**, **Caution**, and **Notice** have the following meanings:

|         |  |
|---------|--|
| DANGER  | DANGER indicates a hazardous situation which, if not avoided, <b>will</b> result in death or serious injury.                                 |
| WARNING | WARNING indicates a hazardous situation which, if not avoided, <b>could</b> result in death or serious injury.                               |
| CAUTION | CAUTION, used with the safety alert symbol, indicates a hazardous situation which, if not avoided, could result in minor or moderate injury. |
| NOTICE  | NOTICE is used to address practices not related to personal injury.  |

### Warranty

- Product warranty will expire 12 months after the product is first taken into use, but will in any case expire at the latest 13 months after delivery.
- Normal wear and tear on parts is not included within the warranty.
  - Normal wear and tear is that which requires a part change or other adjustment/overhaul during standard tools maintenance typical for that period (expressed in time, operation hours or otherwise).
- The product warranty relies on the correct use, maintenance, and repair of the tool and its component parts.
- Damage to parts that occurs as a result of inadequate maintenance or performed by parties other than Desoutter or their Certified Service Partners during the warranty period is not covered by the warranty.
- To avoid damage or destruction of tool parts, service the tool according to the recommended maintenance schedules and follow the correct instructions.
- Warranty repairs are only performed in Desoutter workshops or by Certified Service Partners.

Desoutter offers extended warranty and state of the art preventive maintenance through its Tool Care contracts. For further information contact your local Service representative.

#### For electrical motors:

- Warranty will only apply when the electric motor has not been opened.

### Website

Information concerning our Products, Accessories, Spare Parts and Published Matters can be found on the Desoutter website.

Please visit: [www.desouttertools.com](http://www.desouttertools.com).

### Information about spare parts

Exploded views and spare parts lists are available in Service Link at [www.desouttertools.com](http://www.desouttertools.com).

Dimensions (mm)

EAD

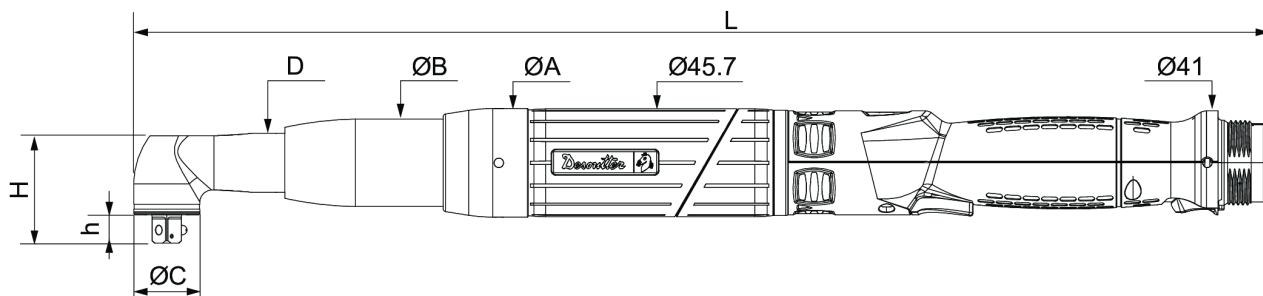

|               | ØA | ØB | D  | L   |
|---------------|----|----|----|-----|
| 20-1300       | 46 | 37 | 25 | 481 |
| 32-900        | 46 | 37 | 25 | 481 |
| 50-900        | 46 | 37 | 28 | 531 |
| 70-800        | 58 | 43 | 32 | 544 |
| 70-800 Sq.1/2 | 58 | 43 | 32 | 544 |
| 80-650        | 58 | 48 | 40 | 567 |
| 105-500       | 58 | 48 | 40 | 567 |

|               | h    | H    | ØC |
|---------------|------|------|----|
| 20-1300       | 12   | 45.5 | 28 |
| 32-900        | 12   | 45.5 | 28 |
| 50-900        | 12   | 51.1 | 35 |
| 70-800        | 12   | 56.7 | 40 |
| 70-800 Sq.1/2 | 17   | 62   | 40 |
| 80-650        | 17.5 | 60.4 | 45 |
| 105-500       | 17.5 | 60.4 | 45 |

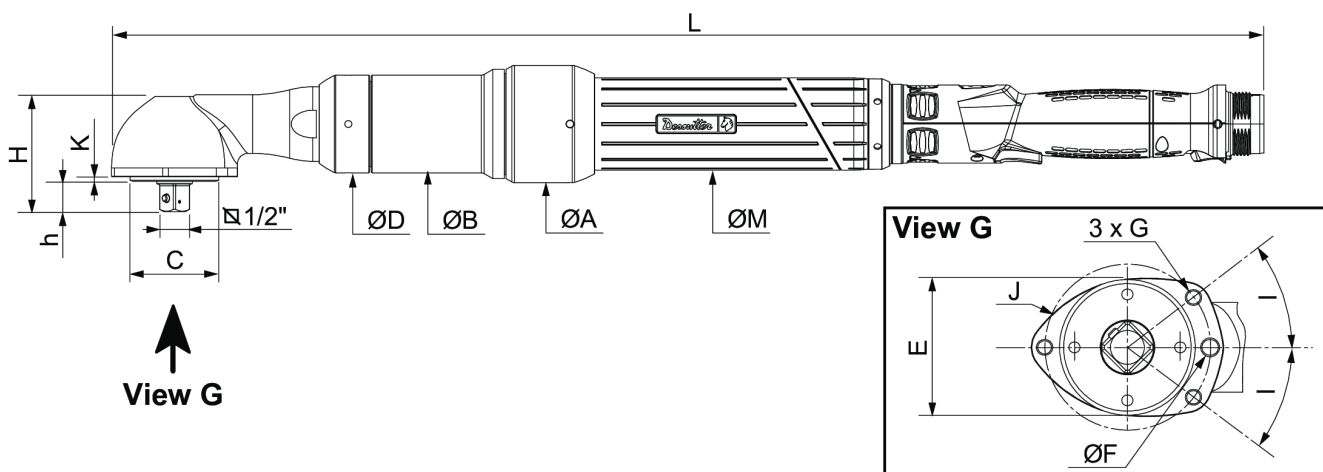

|         | ØA | ØB | M  | L   |
|---------|----|----|----|-----|
| 160-430 | 66 | 55 | 52 | 650 |
| 200-370 | 66 | 55 | 52 | 673 |
| 280-260 | 66 | 55 | 52 | 673 |
| 280-370 | 76 | 55 | 66 | 681 |
| 440-250 | 76 | 67 | 66 | 735 |
| 660-160 | 76 | 67 | 66 | 774 |

|         | C   | E   | F               | G   |
|---------|-----|-----|-----------------|-----|
| 160-430 | 50  | 51  | 6 (0 to 0.012)  | M6  |
| 200-370 | 62  | 63  | 6 (0 to 0.012)  | M6  |
| 280-260 | 62  | 63  | 6 (0 to 0.012)  | M6  |
| 280-370 | 62  | 63  | 6 (0 to 0.012)  | M6  |
| 440-250 | 75  | 76  | 8 (0 to 0.015)  | M8  |
| 660-160 | 106 | 107 | 10 (0 to 0.015) | M10 |

|         | K   | h  | H   | I   | J   |
|---------|-----|----|-----|-----|-----|
| 160-430 | 2.5 | 17 | 65  | 37° | 61  |
| 200-370 | 3.5 | 23 | 85  | 40° | 73  |
| 280-260 | 3.5 | 23 | 85  | 40° | 73  |
| 280-370 | 3.5 | 23 | 85  | 40° | 73  |
| 440-250 | 3.5 | 24 | 91  | 37° | 90  |
| 60-160  | 5   | 33 | 110 | 40° | 121 |

**EAD-HAD**

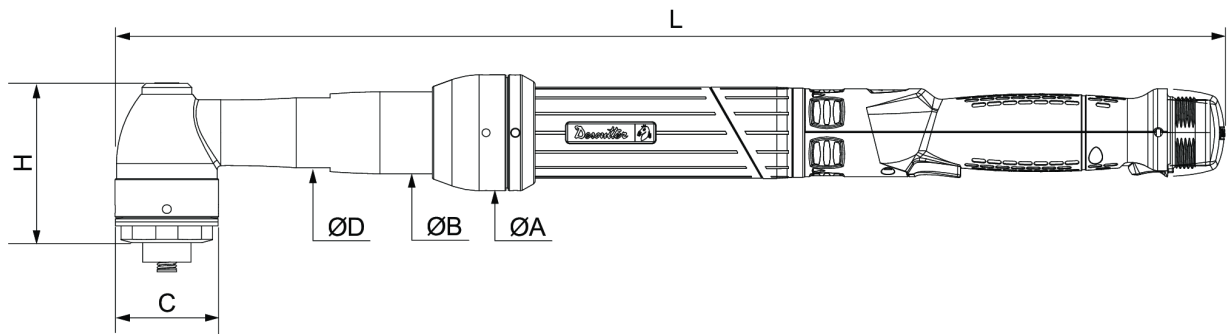

|         | ØA | ØB | C    | D  |
|---------|----|----|------|----|
| 50-900  | 46 | 37 | 36.5 | 28 |
| 70-700  | 58 | 41 | 52   | 35 |
| 105-500 | 58 | 48 | 46   | 40 |

|         | H    | L   |
|---------|------|-----|
| 50-900  | 61.6 | 532 |
| 70-700  | 90   | 550 |
| 105-500 | 88   | 567 |

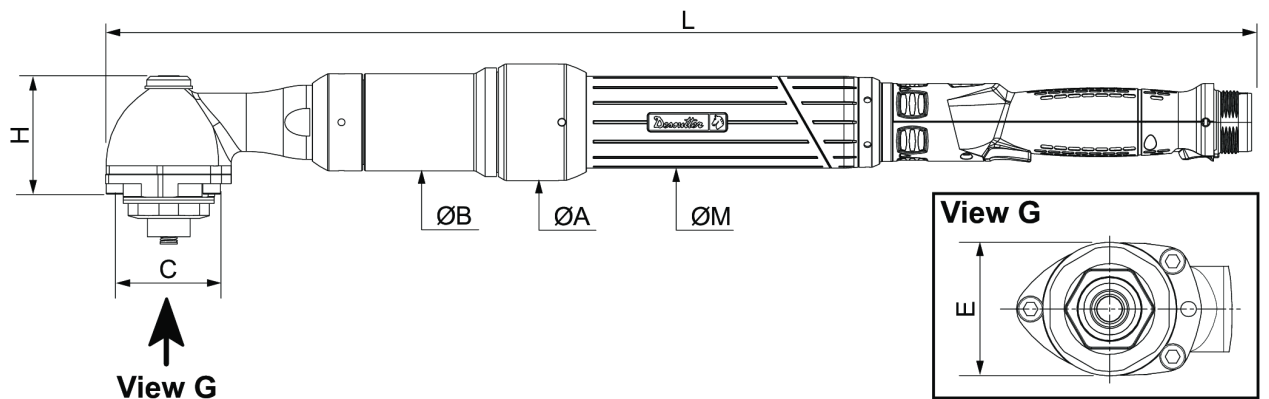

|  | ØA | ØB | C | E |
|--|----|----|---|---|
|--|----|----|---|---|

|         |    |     |    |      |
|---------|----|-----|----|------|
| 160-430 | 66 | 55  | 46 | 51.5 |
|         | H  | L   | ØM |      |
| 160-430 | 91 | 650 | 52 |      |

## CAD files

For information about the dimensions of a product, see the Dimensional drawings archive:

<https://www.desouttertools.com/resource-centre>

## Overview

### General overview

EAD / EAD-HAD are electric angle-head nutrunners powered by one of the following Desoutter controllers.

- CVI3 Essential
- CVI3 Function
- CVI3 Vision
- TWINCVI3

They are hand-held by the operator.

They also can be used as fixtured tools and installed on a frame in the workstation.

Contact your Desoutter representative to get more information and support.

They received the tightening process to run from the controller.

Tools settings such as trigger management, LED management, run reverse mode, etc... can be set up with CVI CONFIG.

Change the orientation of the angle head by mounting an eFLEX cable.

The following models are equipped with *eCompass* feature.

- EAD20-1300
- EAD32-900
- EAD50-900
- EAD70-800
- EAD70-800 SQ1/2
- EAD80-650
- EAD105-500
- EAD160-430
- EAD200-370

This feature is available for tools equipped with a gyroscope.

This feature is used to compensate any movement of the operator that might add or remove angle in the assembly.

Moreover, an angle range (tool angle limits) is defined to stop the tightening if the operator movement is outside this range.

This feature is programmable with CVI CONFIG software.

The ePOD model (ePOD2 Compass) must be connected to the controller.

## Product description

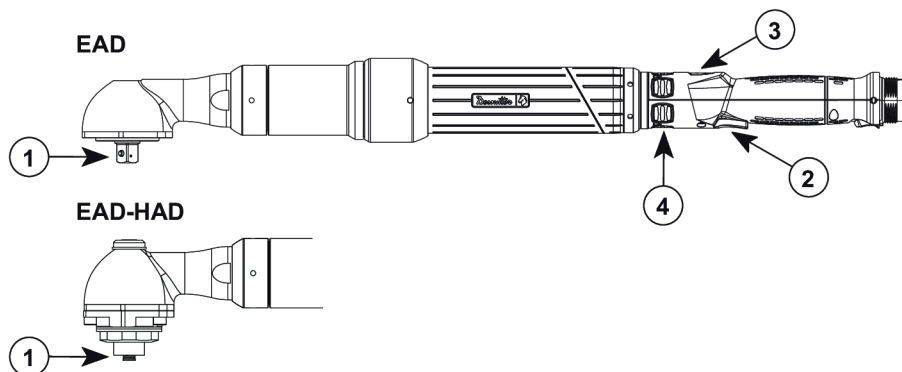

|   |                |
|---|----------------|
| 1 | Output drive   |
| 2 | Trigger        |
| 3 | Reverse button |
| 4 | Reporting LEDs |

## Technical data

### Voltage

3 ~ 230 V

### Power consumption

| Model            | W   |
|------------------|-----|
| EAD20-1300       | 55  |
| EAD32-900        | 55  |
| EAD50-900        | 100 |
| EAD50-900-HAD    | 100 |
| EAD70-700-HAD    | 100 |
| EAD70-800        | 100 |
| EAD70-800 SQ 1/2 | 100 |
| EAD80-650        | 100 |
| EAD105-500       | 100 |
| EAD105-500-HAD   | 100 |
| EAD160-430       | 160 |
| EAD160-430-HAD   | 160 |
| EAD200-370       | 160 |
| EAD280-260       | 160 |
| EAD280-370       | 170 |
| EAD440-250       | 170 |
| EAD660-160       | 170 |

### Output drive

| Model            | Type             |
|------------------|------------------|
| EAD20-1300       | Sq. 3/8"         |
| EAD32-900        | Sq. 3/8"         |
| EAD50-900        | Sq. 3/8"         |
| EAD50-900-HAD    | Hold and Drive * |
| EAD70-700-HAD    | Hold and Drive * |
| EAD70-800        | Sq. 3/8"         |
| EAD70-800 SQ 1/2 | Sq. 1/2"         |
| EAD80-650        | Sq. 1/2"         |
| EAD105-500       | Sq. 1/2"         |
| EAD105-500-HAD   | Hold and Drive * |
| EAD160-430       | Sq. 1/2"         |
| EAD160-430-HAD   | Hold and Drive * |
| EAD200-370       | Sq. 3/4"         |
| EAD280-260       | Sq. 3/4"         |
| EAD280-370       | Sq. 3/4"         |
| EAD440-250       | Sq. 3/4"         |
| EAD660-160       | Sq. 1"           |

\*: socket and bit not supplied

**Torque range (Nm)**

| <b>Model</b>     | <b>Min. / Nominal / Max.</b> |
|------------------|------------------------------|
| EAD20-1300       | 3 / 18 / 20                  |
| EAD32-900        | 5 / 30 / 32                  |
| EAD50-900        | 8 / 45 / 50                  |
| EAD50-900-HAD    | 8 / 45 / 50                  |
| EAD70-700-HAD    | 12 / 65 / 70                 |
| EAD70-800        | 12 / 65 / 70                 |
| EAD70-800 SQ 1/2 | 12 / 65 / 70                 |
| EAD80-650        | 15 / 75 / 80                 |
| EAD105-500       | 20 / 90 / 105                |
| EAD105-500-HAD   | 20 / 90 / 105                |
| EAD160-430       | 35 / 150 / 160               |
| EAD160-430-HAD   | 35 / 150 / 160               |
| EAD200-370       | 60 / 170 / 200               |
| EAD280-260       | 60 / 250 / 280               |
| EAD280-370       | 60 / 250 / 280               |
| EAD440-250       | 100 / 400 / 440              |
| EAD660-160       | 100 / 600 / 660              |

**Torque range (ft.lb)**

| <b>Model</b>     | <b>Min. / Nominal / Max.</b> |
|------------------|------------------------------|
| EAD20-1300       | 2.2 / 13.3 / 14.8            |
| EAD32-900        | 3.7 / 22.1 / 23.6            |
| EAD50-900        | 5.9 / 33.2 / 40.6            |
| EAD50-900-HAD    | 5.9 / 33.2 / 40.6            |
| EAD70-700-HAD    | 8.8 / 47.9 / 51.6            |
| EAD70-800        | 8.8 / 47.9 / 51.6            |
| EAD70-800 SQ 1/2 | 8.8 / 47.9 / 51.6            |
| EAD80-650        | 11.1 / 55.3 / 59.0           |
| EAD105-500       | 14.8 / 66.4 / 77.4           |
| EAD105-500-HAD   | 14.8 / 66.4 / 77.4           |
| EAD160-430       | 26 / 111 / 118               |
| EAD160-430-HAD   | 26 / 111 / 118               |
| EAD200-370       | 44 / 125 / 148               |
| EAD280-260       | 44 / 184 / 207               |
| EAD280-370       | 44 / 184 / 207               |
| EAD440-250       | 74 / 295 / 325               |
| EAD660-160       | 74 / 443 / 487               |

**Rated speed (rpm)**

| <b>Model</b>     | <b>rpm</b> |
|------------------|------------|
| EAD20-1300       | 1300       |
| EAD32-900        | 900        |
| EAD50-900        | 900        |
| EAD50-900-HAD    | 900        |
| EAD70-700-HAD    | 700        |
| EAD70-800        | 800        |
| EAD70-800 SQ 1/2 | 800        |



| <b>Model</b>   | <b>rpm</b> |
|----------------|------------|
| EAD80-650      | 650        |
| EAD105-500     | 500        |
| EAD105-500-HAD | 500        |
| EAD160-430     | 430        |
| EAD160-430-HAD | 430        |
| EAD200-370     | 370        |
| EAD280-260     | 260        |
| EAD280-370     | 370        |
| EAD440-250     | 250        |
| EAD660-160     | 160        |

### **Weight**

| <b>Model</b>     | <b>kg</b> | <b>lb</b> |
|------------------|-----------|-----------|
| EAD20-1300       | 1.55      | 3.41      |
| EAD32-900        | 1.55      | 3.41      |
| EAD50-900        | 1.95      | 4.30      |
| EAD50-900-HAD    | 1.80      | 3.96      |
| EAD70-700-HAD    | 2.00      | 4.40      |
| EAD70-800        | 2.15      | 4.74      |
| EAD70-800 SQ 1/2 | 2.15      | 4.74      |
| EAD80-650        | 2.55      | 5.62      |
| EAD105-500       | 2.55      | 5.62      |
| EAD105-500-HAD   | 2.40      | 5.29      |
| EAD160-430       | 4.45      | 9.81      |
| EAD160-430-HAD   | 4.3       | 9.5       |
| EAD200-370       | 5.25      | 11.57     |
| EAD280-260       | 5.25      | 11.57     |
| EAD280-370       | 6.35      | 13.99     |
| EAD440-250       | 8.65      | 19.07     |
| EAD660-160       | 11.25     | 24.80     |

### **Storage and use conditions**

|  |                              |
|--|------------------------------|
| Storage temperature                      | -20 to +70 °C (-4 to +158 F) |
| Operating temperature                    | 0 to 45 °C (32 to 113 F)     |
| Storage humidity                         | 0-95 % RH (non-condensing)   |
| Operating humidity                       | 0-90 % RH (non-condensing)   |
| Altitude up to                           | 2000 m (6562 feet)           |
| Usable in Pollution degree 2 environment |                              |
| Indoor use only                          |                              |

### **Accessories**

#### **Optional accessories**

|                              |            |
|------------------------------|------------|
| Barcode reader and headlight | 6158121380 |
| Headlight                    | 6158121390 |
| Trigger locker               | 6153978420 |

|   |            |
|---|------------|
| Front trigger (mechanical) for EAD20 to EAD105<br>Warning: this trigger must be mounted on tool by authorized<br>Desoutter technician only. | 6153985300 |
| Front trigger (electric) for EAD20 to EAD32   | 6159110135 |
| Front trigger (electric) for EAD50 to EAD105  | 6159110125 |
| Suspension bail (up to EAD105 / EID75)  | 6153974130 |
| Suspension bail (for EAD160-200-280-660 / EID120)   | 6155710720 |
| Protective cover for EAD20/EAD32  | 6155732070 |
| Protective cover for EAD50  | 6155732080 |
| Protective cover for EAD70  | 6155732090 |
| Protective cover for EAD80/EAD105   | 6155732100 |
| Handle lever  | 6153978310 |

## eFLEX tool cable

| Length (m) | Length (ft) | Part number |
|------------|-------------|-------------|
| 2.5        | 8.20        | 6159176310  |
| 5          | 16.0        | 6159176320  |

## Telescopic modules

|                               |            |
|-------------------------------|------------|
| Telescopic module AHE5 - 1/2" | 6153980760 |
| Telescopic module AHE6 - 3/4" | 6153980770 |
| Telescopic module AHE7 - 3/4" | 6153980780 |
| Telescopic module AHE8 - 1"   | 6153981610 |

## Where-used list

|            |             |             |             |           |
|------------|-------------|-------------|-------------|-----------|
| EAD160-430 | AHE5 - 1/2" | -           | -           | -         |
| EAD280-260 | -           | AHE6 - 3/4" | -           | -         |
| EAD280-370 | -           | AHE6 - 3/4" | -           | -         |
| EAD440-250 | -           | -           | AHE7 - 3/4" | -         |
| EAD660-160 | -           | -           | -           | AHE8 - 1" |

**Required accessories**

## Tool cables

| Length (m) | Length (ft) | Part number |
|------------|-------------|-------------|
| 2.5        | 8.20        | 6159176010  |
| 5          | 16.0        | 6159176020  |
| 10         | 32.8        | 6159176040  |
| 15         | 49.2        | 6159176050  |

## Tool extension cables

| Length (m) | Length (ft) | Part number |
|------------|-------------|-------------|
| 8          | 26.2        | 6159175810  |
| 16         | 52.5        | 6159175840  |
| 32         | 105         | 6159175870  |
| 50         | 164         | 6159175890  |

**Service Overview****Maintenance program**

Please consult us on the **Tool Care** program that includes production support and maintenance solutions.

**Spare parts**

Exploded views and spare parts lists are available at <https://www.desouttertools.com/resource-centre>.

The use of spare parts other than those originally supplied by the manufacturer may result in a drop in performance or in increased maintenance and level of vibration and in the full cancellation of the manufacturer's liability.

## Installation

### Installation Instructions

#### How to clamp the tool

- i** Whether the tool is handled by an operator with a torque arm or embedded in a robot with high dynamics, it is advised to select two clamping locations instead of one.

Before selecting where to clamp the tool, take into account the following instructions.

From EAD20-1300 to EAD105-500

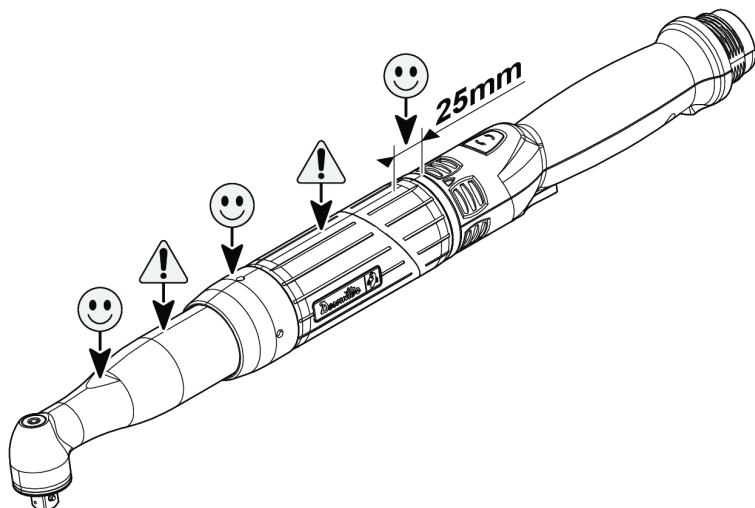

From EAD160-430 to EAD660-160

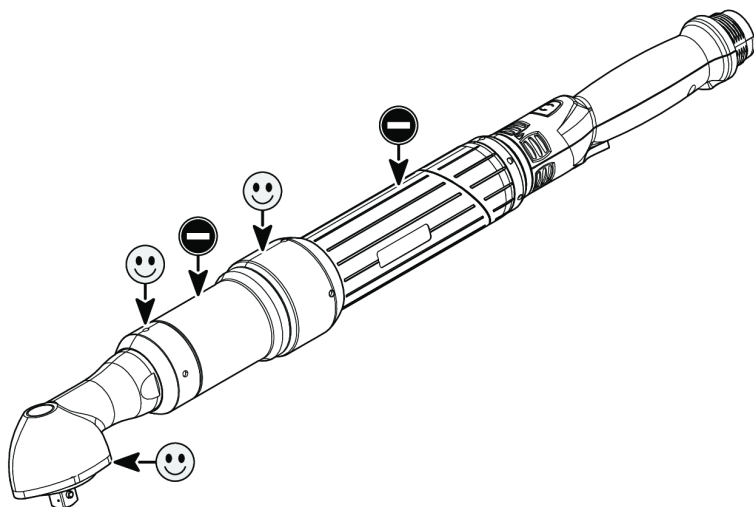

- A** Dedicated clamping area for torque reaction.
- ☺ Preferred clamping area.
- ⚠ This clamping area can be used as a secondary clamping. Do not use this area for torque reaction.
- ⊘ Prohibited clamping area.

- i** Clamping on the motor shall always be selected as the very last option and the operation shall be done with extra care.

## Connecting the tool to the controller

1. Connect the cable to the tool.

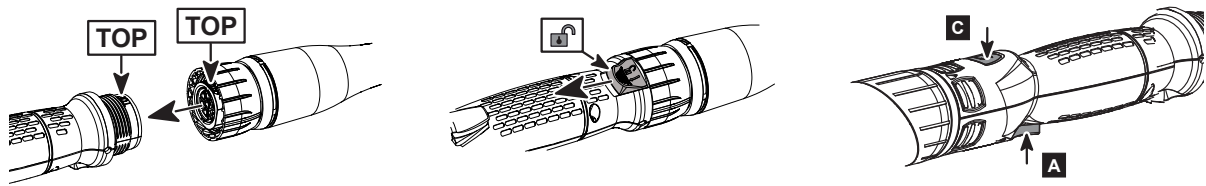

Plug the cable with help of TOP indication.

Tighten the nut. No need to tighten it too much.

The locking system will prevent any loosening.

To enable the loosening of the cable, actuate the locking trigger at the bottom of the handle.

2. Connect the cable to the controller.

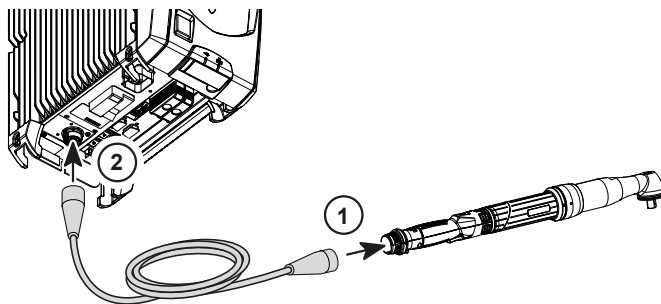

## Mounting the trigger locker

Follow the instructions below.

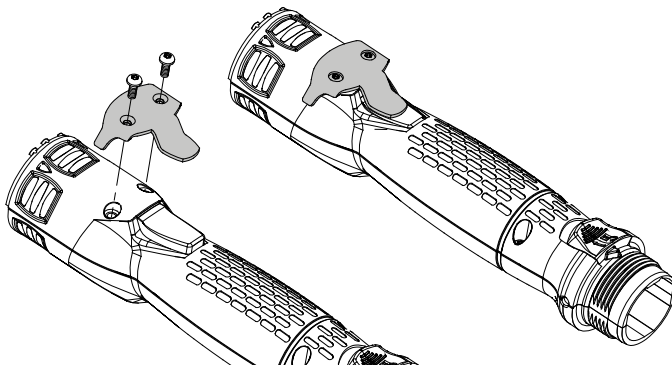

## How to install optional accessories

Refer to the user manual dedicated to the accessory available at <https://www.desouttertools.com/resource-centre>.

## Operation

### Configuration Instructions

#### How to set up the reverse mode

Go to CVI CONFIG to set up the *run reverse* settings.

Refer to the *Configuration Manual* of CVI CONFIG (printed matter: 6159925470) available at <https://www.desouttertools.com/resource-centre>.

#### How to set up the tool as a fixtured tool

Desoutter should not be held responsible for any injury, accident or damage which may be the consequence of an incorrect installation, modification or start-up, or a use out of the intended use of Desoutter products, by the customer or a third party.

This tool can be used as a fixtured tool installed on a frame in the workstation.

#### **WARNING Risk Of Electric Shock**

The frame where tools are clamped must be **earthed**.

In this case, the tool trigger must be locked by the optional accessory *Trigger locker*.

The tightening operation is then triggered by an external start.

The external start can be a remote pushbutton or a PLC output signal sent to the controller.

### Operating Instructions

#### Starting the tool

#### **WARNING Risk Of Injury**

As the reaction force increases in proportion to the tightening torque, there is a risk of severe bodily injury of the operator as a result of unexpected behavior of the tool.

- Make sure that the tool is in perfect working order and the system is programmed correctly.

Fit the tool with a suitable socket.

Select the appropriate program on the controller.

Hold the tool by means of the handle and apply to the fastener to be tightened.

Press the trigger to start the tool.

#### How to reverse the rotation

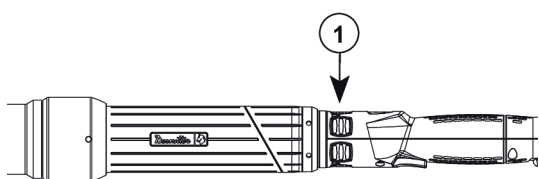

---

|   |                    |
|---|--------------------|
| 1 | Run reverse button |
|---|--------------------|

---

Press this button.

Red and green LEDs are blinking alternatively.

Apply the tool to the fastener and press the trigger.

## Tightening status and LED reporting

### Reporting LEDs

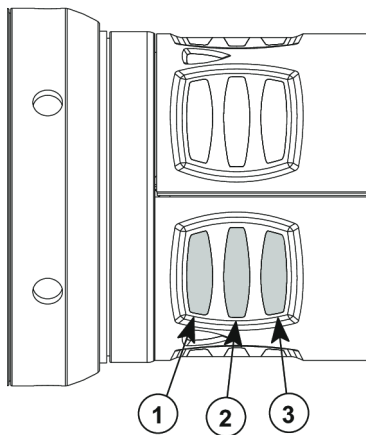

|   |        |
|---|--------|
| 1 | Red    |
| 2 | Green  |
| 3 | Yellow |

### How to read the tightening report

| LED color               | Description        | Action to do                                    |
|-------------------------|--------------------|---|
| Green                   | Accept report      | None  |
| Yellow                  | Incomplete rundown | Tighten again.                                  |
| Yellow and red (orange) | Reject report      | Loosen and tighten again.                       |
| Red                     | Above max. limits  | Loosen, replace the fastener and tighten again. |

## Service

### ***Maintenance Instructions***

#### **Instructions for transducerized tools**

- Do not damage the wires when pulling out the connectors.
- Do not pull out the torque transducer wires.
- Ensure that wires are not crushed.

#### **Read before maintenance**

##### **WARNING Connection Hazard**

The tool can start unexpectedly and cause severe bodily injury.

- ▶ Prior to any maintenance task, disconnect the tool.

Maintenance should be performed by **qualified personnel only**.

Follow standard engineering practices and refer to exploded views for disassembling and reassembling the different parts of the system.

Take into account the following instructions given in the exploded views.

Be cautious: when reassembling, tighten the right direction.



Left hand thread



Right hand thread

When reassembling:



Apply the recommended glue.



Tighten to the required torque.



Lubricate with the required grease or oil. Do not apply too much grease on gears or bearings; a thin coat shall be sufficient.

### **Preventive Maintenance**

#### ***Recommendations***

Overhaul and preventive maintenance are recommended at regular intervals once per year or after a maximum number of tightenings (refer to the table below) depending on which occurs sooner.

#### ***Maintenance frequency***

500,000 tightenings

#### ***Heavy duty***

Heavy duty use can require more frequent overhaul and Preventive Maintenance intervals. Please contact your local Desoutter Service team to get a customized maintenance plan.

### **Upgrading tools**

To upgrade tools, it is necessary to have:

- an ACCESS KEY USB stick set with the right profile.  
This USB stick is provided by your CVIKEY manager.
- CVIMONITOR software

Contact your Desoutter representative to get more information and support.



***Checking before putting back into service***

Prior to putting the equipment back into service, check that its main settings have not been modified and that the safety devices work properly.

***Recommissioning***

Prior to putting the different parts of the system back into service, check that the main settings have been correctly set up and that the safety devices work properly.





Original instructions

Founded in 1914 and headquartered in France, Desoutter Industrial Tools is a global leader in electric and pneumatic assembly tools serving a wide range of assembly and manufacturing operations, including Aerospace, Automotive, Light and Heavy Vehicles, Off-Road, General Industry.

Desoutter offers a comprehensive range of Solutions -tools, service and projects- to meet the specific demands of local and global customers in over 170 countries.

The company designs, develops and delivers innovative quality industrial tool solutions, including Air and Electric Screwdrivers, Advanced Assembly Tools, Advanced Drilling Units, Air Motors and Torque Measurement Systems.

**Find more on [www.desouttertools.com](http://www.desouttertools.com)**



**More Than Productivity**